

Main Drive Components

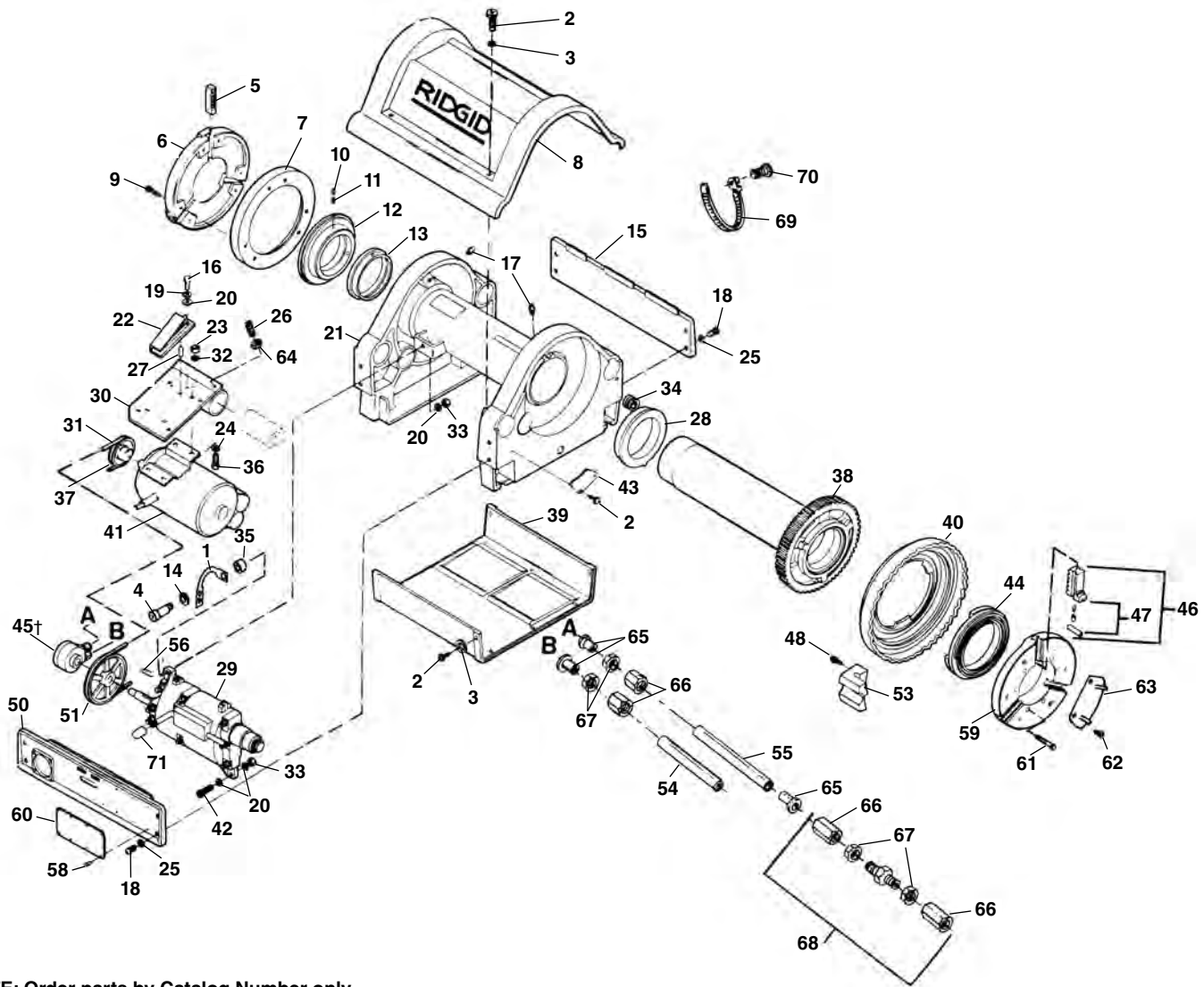

**NOTE: Order parts by Catalog Number only.
DO NOT order by Reference Number.**

Ref. No.	Catalog No.	Description	Ref. No.	Catalog No.	Description	Ref. No.	Catalog No.	Description
1	33622	Pump Bracket	25	40930	Lock Washer 3/8" (8)	46	40087	Chuck Jaw Set
2	41597	Screw (12)	26	88265	Set Screw 3/8" - 16 x 1"	47	47517	Chuck Jaw Set Pl. Ctd. Pipe
3	41592	Washer (10)	27	88230	Roll Pin 1/4" x 9/16"	47	54212	Jaw Insert Set
4	33627	Screw	28	26767	Front Bearing	26247	26247	Jaw Insert Set F/Coated Pipe
5	32412	Centering Jaw Set	29	26362	Gear Box Assy.	48	27067	Self-Tapping Screw (2 Req. f/G.S.)
6	26537	Centering Head	30	27062	Motor Bracket	50	59722	Front Side Plate
7	26542	Back Plate	31	26832	V-Belt	51	26852	Gear Box Pulley
8	26477	Top Cover	32	40770	Lock Washer 5/16" (4)	53	26507	Pinch Point Cover Boss (2 Req. f/G.S.)
	46867	Die Head Decal (Not Shown)	33	27517	Lock Nut 5/16" - 18	54	27007	Inlet Hose
9	40910	Screw 1/4" - 20 x 3/4" (6)	34	47080	Grommet	55	26822	Output Hose
10	45300	Set Screw 5/16" - 24 x 1/4" (3)	35	33617	Spacer	56	27002	Key
11	45265	Set Screw 5/16" - 24 x 1/2" (3)	36	85910	Bolt 5/16" - 18 x 1 1/4"	58	85920	Rivets (8)
12	32407	Scroll	37	26857	Motor Pulley (60 Hz)	59	26332	Chuck Cap
13	26352	Rear Bearing		27082	Motor Pulley (50 Hz)	60	88690	Safety Plate
14	26307	Washer	38	26347	Drive Gear/Spindle Assy.	61	26522	Screw 5/16" - 24 x 2 1/4" (6)
15	26487	Rear Side Plate	39	26482	Bottom Cover	62	27242	Screw 10 - 32 (6)
16	32145	Screw 1/4" - 20 x 1/2"	40	26337	Handwheel	63	33612	Set of 3 Cover Plates
17	46860	Grease Fitting (2)	41	26237	Motor w/Capacitor 120V, 60 Hz	64	83545	Jam Nut 3/8" - 16
18	26997	Screw 3/8" - 16 x 3/4" (8)		27287	Motor w/Capacitor 110V, 50 Hz	65	35117	Tube Insert (3)
19	44740	Lock Washer 1/4"		26232	Motor w/Capacitor 240V, 60 Hz	66	40602	Compression Nut
20	96740	Washer 5/16"		27282	Motor w/Capacitor 220/240V, 50 Hz	67	40607	Ferrule
21	26357	Base	42	27037	Shoulder Bolt	68	26972	Union
22	26492	Belt Tensioner	43	27012	Pinion Guard	69	43552	Tie Down Strap
23	96730	Nut 5/16" - 18 (4)	44	26517	Scroll	70	45275	Screw 10 - 24 x 1/2"
24	27402	Washer 5/16" (4)	45†	27307	Oil Pump	71	27032	Shifter Knob

60 Hz Electrical Components

NOTE: Order parts by Catalog Number only. DO NOT order by Reference Number.

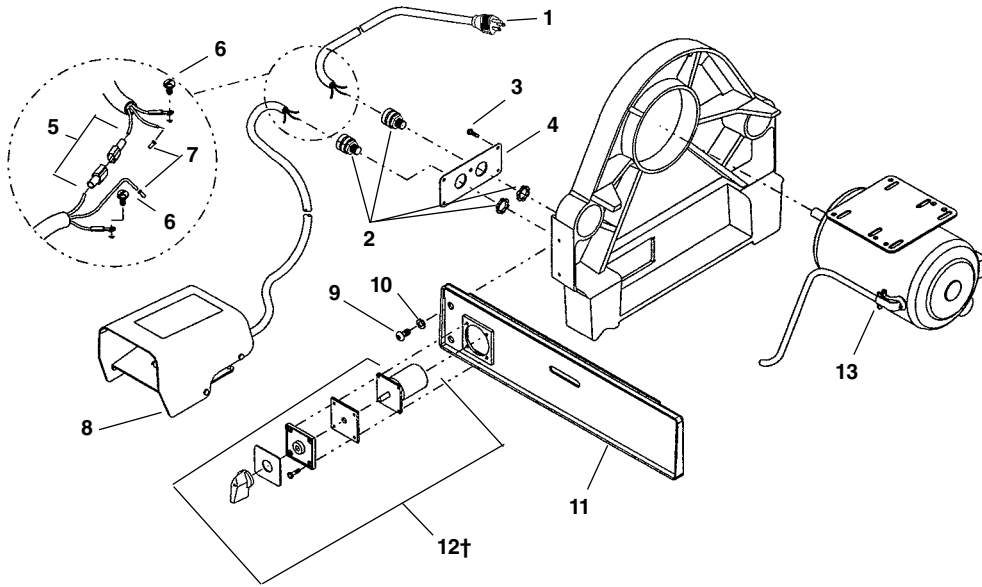

Ref. No.	Catalog No.	Description
1	46740	Power Cord
	46410	Power Cord
2	75977	Strain Relief (2)
3	41597	Self Tapping Screw (4)
4	27162	Strain Relief Bracket
5	56407	Quick Disconnect Set
6	45420	Ground Screw
7	36222	Wire Terminal
8	36642	B-294 Foot Switch
9	26997	Screw 3/8" - 16 x 3/4" (8)
10	40930	Lock Washer 3/8" (8)
11	59722	Front Side Plate
12†	20113	Switch Assembly
13	26237	Motor 120V 60 Hz
	26232	Motor 240V 60 Hz

† Ref. No. 12 – When replacing early style switches, which have a black body, order Catalog No. 59742 Switch Adapter Plate

1224 & 1822-I Replacement Switch Wiring Diagram

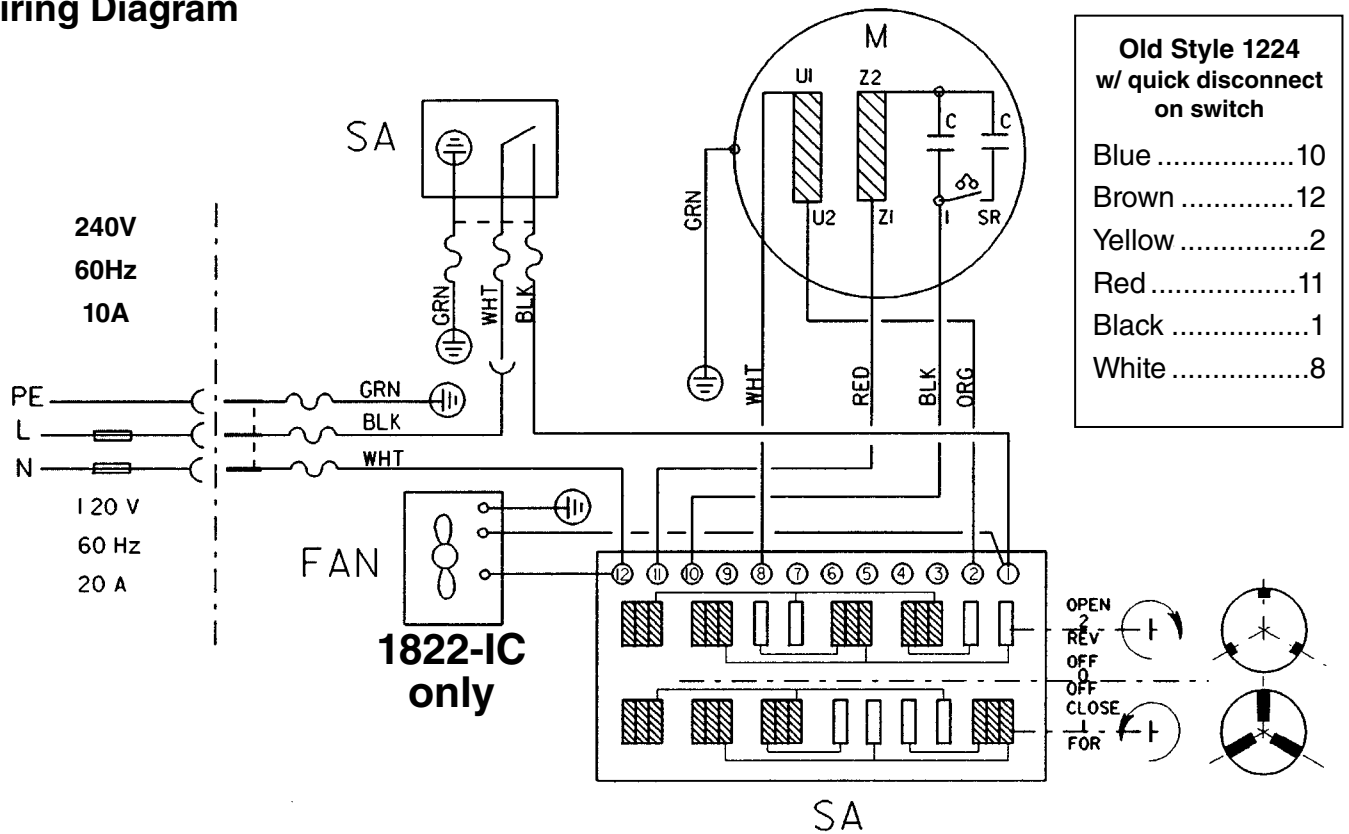

50 Hz Electrical Components

NOTE: Order parts by Catalog Number only.
DO NOT order by Reference Number.

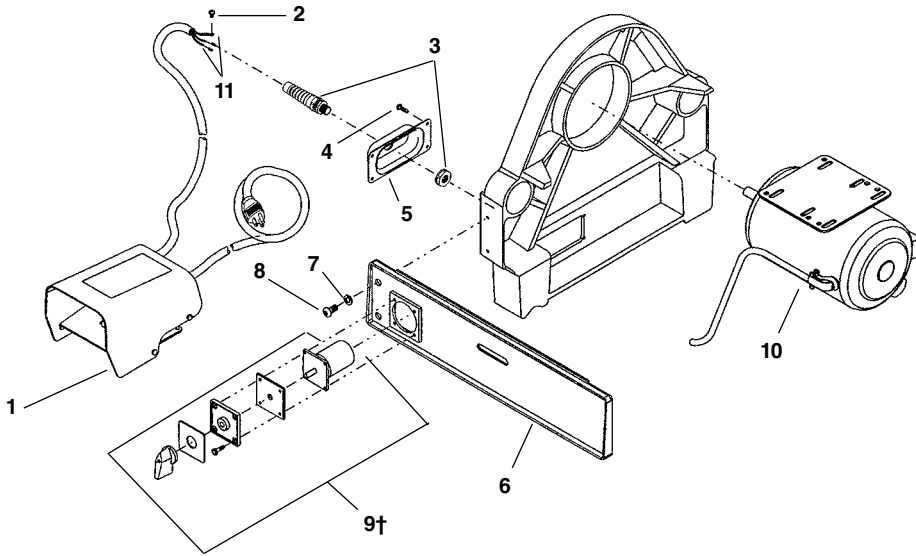

Ref. No.	Catalog No.	Description
1	36652	B-296 Foot Switch
	36657	B-297 Foot Switch
2	45420	Ground Screw
3	27187	Strain Relief
4	41597	Self Tapping Screw (4)
5	27197	Strain Relief Bracket
6	59722	Front Side Plate
7	40930	Lock Washer 3/8" (8)
8	26997	Screw 3/8" - 16 x 3/4" (8)
9†	20113	Switch Assembly
10	27282	Motor 220/240V 50 Hz
	27287	Motor 110V 50 Hz
11	36222	Wire Terminal

† Ref. No. 12 – When replacing early style switches, which have a black body, order Catalog No. 59742 Switch Adapter Plate

1224 & 1822-I Replacement Switch Wiring Diagram

